

Macadams D16 & D20 Divider



FEATURES & BENEFITS

- SOFT DOUGH HANDLING WITH NO EXCESS COMPRESSION.
- EMERGENCY STOP BUTTON.
- HEAVY FRAMED BODY.
- EASY CONTROLS.



Technical Specs

Macadams D16 & D20 Divider

Contact Details

HEAD OFFICE, EXPORTS & CAPE TOWN BRANCH

Private Bag X7, Kuils River, 7579,
South Africa.

Tel : +27 (21) 907-1000

Fax : +27 (21) 907-1111

JOHANNESBURG BRANCH

Tel : (011) 472-4100

Fax : (011) 472-4154

DURBAN BRANCH

Tel : (031) 569-6290

Fax : (031) 569-6296

EMAIL

info@macadams.co.za

WEBSITE

www.macadams.co.za

We reserve the right to both
technical and design
modifications.

February 2009

| | |
|--------------------------------------|---|
| Power Rating | 1.5 kW |
| Power Supply | 220/380 V, 50 Hz, 6/3.5 Amp |
| Number of Divisions | D 16 : 16 (16 kg) D 20 : 20 (16 kg) |
| Weight Range for Dough Pieces | D 16 : 100 - 1000g D 20 : 100 - 800g |
| Dimensions (mm) | 570 (w) x 695 (d) x 1080 (h) |
| Weight: | |
| Nett | 280 kg |
| Gross | 320 kg |

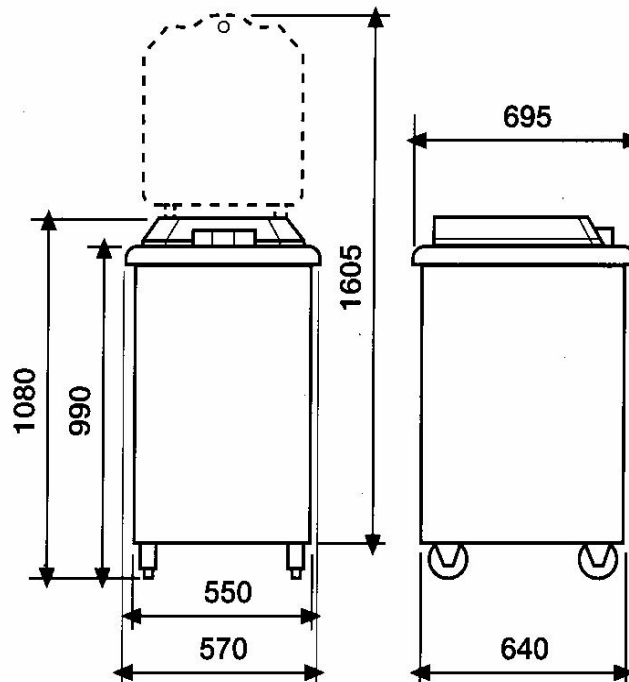

The Company. The People. The Products.

