

Macadams Eco-Line Bread Line



FEATURES & BENEFITS



- WEIGHT RANGE: 120 - 1200 GRAMS (HANDER UP SYSTEM).
- THROUGHPUT: 520 - 1200 PIECES / HOUR. VARIABLE SPEED.
- POCKET NET: 132 PIECES.
- PROVING TIME: 1200 PIECES/HOUR = 6.6 MINUTES
800 PIECES/HOUR = 9.9 MINUTES
- 1000 PIECES/HOUR = 7.9 MINUTES
600 PIECES/HOUR = 13.2 MINUTES

Technical Specs

Macadams Eco-Line Bread Line

	DOUGH DIVIDER SD-180	HANDER UP SYSTEM	POCKET PROVER IPP-6/22	MOULDER MO-671
Weight Range	120 - 1600 gram	120 - 1600 gram	100 - 1500 gram	30 - 1800 gram
Capacity Range	520 - 1175 pcs/hr	520 - 1175 pcs/hr	Up to 1200 pcs/hr	Up to 3000 pcs/hr
Dimensions (mm)	1510 x 670 x 1650	875 x 435 x 265	1860 x 7930 x 2600	2120 x 895 x 1860

Contact Details

HEAD OFFICE, EXPORTS & CAPE TOWN BRANCH

Private Bag X7, Kuils River, 7579,
South Africa.

Tel : +27 (21) 907-1000

Fax : +27 (21) 907-1111

JOHANNESBURG BRANCH

Tel : (011) 472-4100

Fax : (011) 472-4154

DURBAN BRANCH

Tel : (031) 569-6290

Fax : (031) 569-6296

EMAIL

info@macadams.co.za

WEBSITE

www.macadams.co.za

We reserve the right to both technical and design modifications.

February 2009

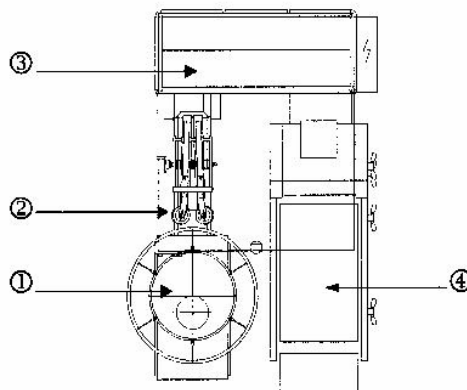
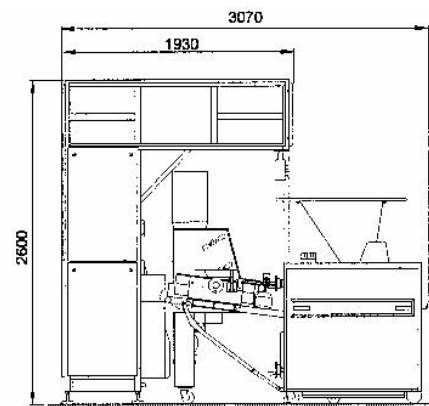
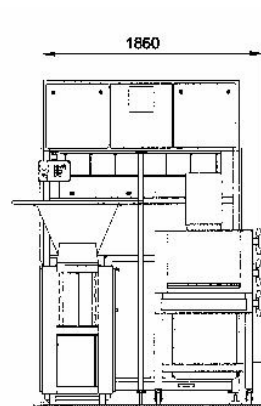

- ① Dough Divider SD-180
- ② Hander-up system
- ③ Pocket Prover IPP-6/22
- ④ Moulder MO-671

The Company. The People. The Products.

