

Macadams Straight Dough Line



FEATURES & BENEFITS



- WEIGHT RANGE: 70 - 1000 GRAMS (SD-180 XS), 150 - 1200 GRAMS (CE-100 I), 30 - 1800 GRAMS (MO-671 MIDI).
- THROUGHPUT: 750 - 1800 PIECES/HOUR (SD-180 XS), UP TO 1800 PIECES/HOUR (CE-100 I), UP TO 3000 PIECES/HOUR (MO-671 MIDI).

Technical Specs

Macadams Straight Dough Line

	SD-180 XS SUCTION DOUGH DIVIDER	CE-100 I CUP ELEVATOR, without base	MO-671 MOULDER "MIDI"
Weight Range	70 - 1000 g	150 - 1200 g	30 - 1800 g
Capacity Range	750 - 1800 pieces/hour	Up to 1800 pieces/hour	Up to 3000 pieces/hour
Power Supply	400V, 1.1kW, 2.6A/fuse 16A	400V, 0.55kW, 1.5A/fuse 10A or 230V, 0.55kW, 2.7A/fuse 10A	1.1kW
Variable Speed	520 - 1200 pieces/hour	-	-
Hopper	100-litre	-	-
Working Width	-	-	Up to 650 mm
Dimensions (mm)	670 (w) x 1510 (l) x 1646 (h)	1360 (l) x 2000 (h)	820 (w) x 2120 (l) x 1870 (h)
Weight:			
Net	540 kg		550 kg
Gross	600 kg		610 kg

Contact Details

HEAD OFFICE, EXPORTS & CAPE TOWN BRANCH

Private Bag X7, Kuils River, 7579,
South Africa.

Tel : +27 (21) 907-1000

Fax : +27 (21) 907-1111

JOHANNESBURG BRANCH

Tel : (011) 472-4100

Fax : (011) 472-4154

DURBAN BRANCH

Tel : (031) 569-6290

Fax : (031) 569-6296

EMAIL

info@macadams.co.za

WEBSITE

www.macadams.co.za

We reserve the right to both
technical and design
modifications.

February 2009

SD-180 XS SUCTION DOUGH DIVIDER CE-approved hopper guard. Stainless steel covers. Stainless steel dough knife. 5 m connection cable and CEE-plug. Frequency converter drive.	CE-100 I CUP ELEVATOR, without base Photocell controlled, working step by step to link up cone rounder with moulder type MO-671. With electric cabinet mounted on elevator.	MO-671 MOULDER "MIDI" Two pair of rollers. Foldable pressure board with two wedges in food approved plastic.
--	---	---

ACCESSORIES for SD-180
 Flour duster, mechanical (stainless
 steel).
 Hander-up system mounted on
 extended outlet conveyor.

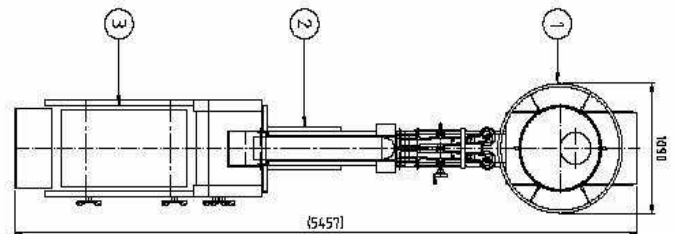

- 1 - Dough Divider SD 180 XS with Hander Up
- 2 - Cup Elevator CE 100
- 3 - Moulder MO 671

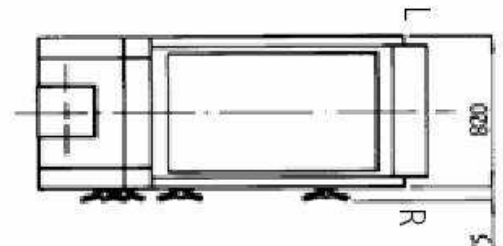
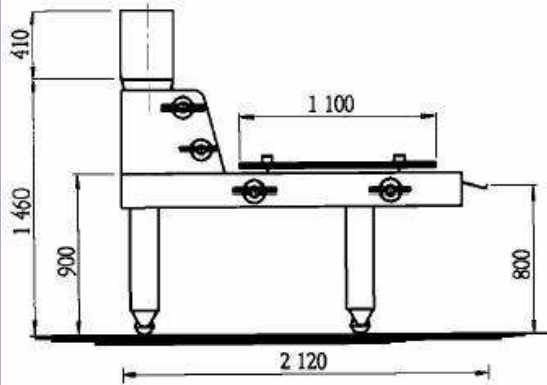

The Company. The People. The Products.

