

BL Bowl Lift



Glimek BL is a solid bowl lift for lifting and tipping a bowl into a bulk hopper, directly into a divider or other similar applications. The lifting capacity is up to 600 kg load (bowl including dough). Standard version adapted to Glimek Mixers 120, 160 and 240 kg dough.



Sveba Dahlen Group

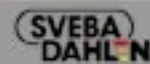

Scandinavian know-how – worldwide

BL Bowl Lift

Lift speed 5,0 meters/min

Lift capacity 600 kg
(bowl including dough)



Safety guard with safety switch has to be in closed (secured) position in order to lift the bowl



Two gear motors lifts the bowl by two separate chains, each provided with a chain tension sensor



The lift is controlled with push buttons for up and down movement

Accessories

Bowl lift designed for bowls from other manufactures	The lift can be modified to fit bowls from other manufactures, however this has to be approved by Glimek technical department by order
Higher tipping height	For tipping height over 3000 and up to maximum 4000 mm
Straight forward tipping	Tipping in the same direction as the infeed of the bowl Side of column has to be stated when ordering

Technical data

Max total height	4250 mm
Max tipping height	3000 mm with Glimek SM-241 bowl
Lifting capacity	600 kg
Lifting speed	5,0 meters/min
Power supply	1,1 kW

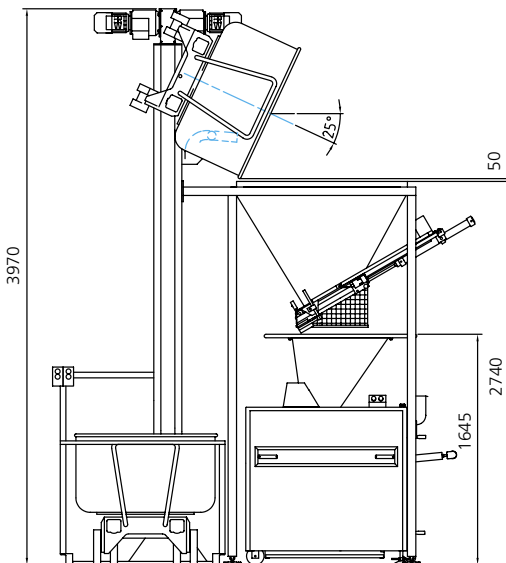

Lift can be made for left hand, right hand or straight a head tipping, please specify by order
All orderconfirmations of bowl lift includes a technical drawing



Glimek AB
Box 124
S-280 64 GLIMÅKRA
Sweden
Tel. int. +46-(0)44 449 00 • Fax +46-(0)44 449 10
e-mail: office@glimek.se • www.glimek.se