

SM-161/241M Spiral Mixer



Glimek SM 161/241M is a heavy duty mixer with mobile bowl and two motors designed for industrial bakeries. When starting the machine the mixing head is lowered and the bowl is slightly raised and automatically positioned to the drive unit.



Sveba Dahlen Group

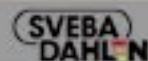

Scandinavian know-how – worldwide

SM-161/241M Spiral Mixer

At the end of the mixing cycle the machine stops, the head lifts automatically and the bowl is released



Easy to move the bowl thanks to big rubber wheels equipped with ball bearings



The control panel has push buttons for on/off, up/down, manual/automatic, slow/fast and two electric timers

Bottom frame and mixing head of cast iron

Accessories

Extra bowl for SM-161M	For 160 kg dough
Extra bowl for SM-241M	For 240 kg dough
Scraper in food approved plastic material	Scraper for release dough from bowl. With spring tension. Works all the way down to bowl bottom. This unit can also be used on existing machines
Stainless steel beater	Replace standard spiral, for other type of mixing
Increasing of speed on beater, 30%	Increasing speed of beater with 30%, for mixing in air into the product

Technical data SM-161M

Flour	100 kg
Dough	160 kg
Power supply	12,8 kW
Weight net, incl bowl	1710 kg
Weight, gross (wooden crate)	1820 kg
Volume, gross	2,05 x 1,35 x 1,63 = 4,51 m ³

Extra bowl SM-161M

Weight, net	225 kg
Weight, gross (wooden crate)	320 kg
Volume, gross	1,29 x 1,20 x 1,17 = 1,81 m ³

Technical data SM-241M

Flour	150 kg
Dough	240 kg
Power supply	12,8 kW
Weight net, incl bowl	1745 kg
Weight, gross (wooden crate)	1855 kg
Volume, gross	2,05 x 1,35 x 1,63 = 4,51 m ³

Extra bowl SM-241M

Weight, net	260 kg
Weight, gross (wooden crate)	355 kg
Volume, gross	1,29 x 1,20 x 1,17 = 1,81 m ³

Specify the bowl size by order, SM161M for 160 kg dough and SM241M for 240 kg dough

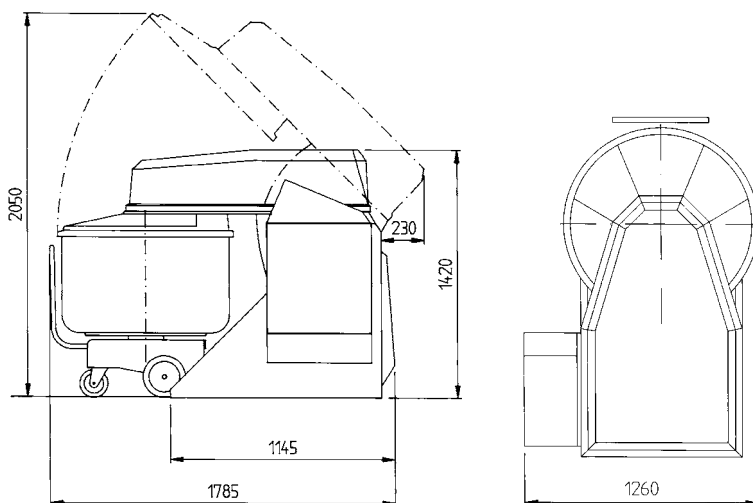

Glimek AB
 Box 124
 S-280 64 GLIMÅKRA
 Sweden
 Tel. int. +46-(0)44 449 00 • Fax +46-(0)44 449 10
 e-mail: office@glimek.se • www.glimek.se