



# Macadams Hopper Topper (Econo & HTPL Pump System)



## FEATURES & BENEFITS

- All stainless steel piston pump unit.
- Mobile all stainless steel construction stand
- Adjustable height to suit customer's mixing bowl.
- Unique tilting mechanism allows for easy changing of bowls
- Automatic start/stop hopper level control sensor, enclosed in a nema 4x control box.
- 2" diameter flexible outlet hose with "u" pipe on the end to hook onto the rim of the hopper.
- The hopper topper pl is power lift model with a extra 8" extended lift distance and deeper bowl depth capabilities



	ECONO	HTPL
Power	Air/Electric 100 PSI @ 4CFM, 110V, 1 Amp, single phase or 220V 6.9 Bar @ 226.5 litres/minute	Air Compression 4-12 CFM @ 80 PSI
Speed	Variable with air pressure regulator.	
Volume (l/min)	11 - 49	Max 60-79
Cube Size	Up to 25 mm cube soft fruit or similar.	
Dimensions (mm)	762 (W) x 1474 (L) x 840 (H)	
Max. Bowl Height	Rim 1110 mm from ground level.	Rim 1110mm from ground level
Max. Reach - to bottom of bowl	660 mm from the bowl rim.	
Weight (kg)	113	

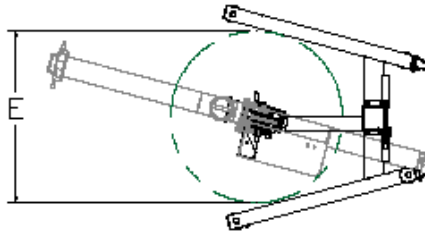

<b>A</b>	Tilt Height	1290 mm
<b>B</b>	Maximum Bowl rim clearance in up position	1040 mm
<b>C</b>	Distance between Pump inlet and outlet (Maximum Bowl Depth)	620 mm
<b>D</b>	Maximum pump to floor clearance	420 mm
<b>E</b>	Inside Width	636 mm
<b>F</b>	Bottom Frame Height	153 mm

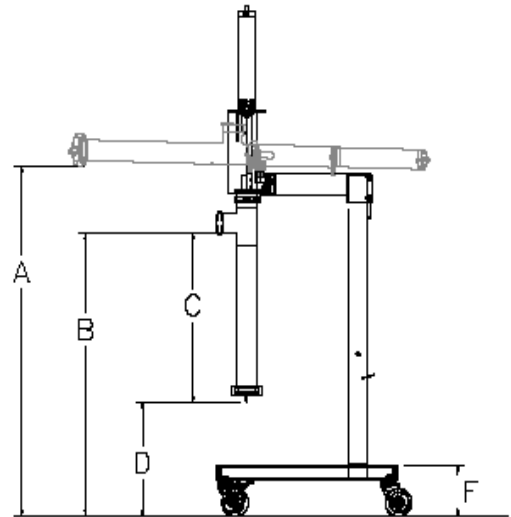

## Contact Details

HEAD OFFICE, EXPORTS & CAPE TOWN BRANCH Tel : +27 (21) 907-1000 Fax : +27 (21) 907-1111

JOHANNESBURG BRANCH Tel : (011) 472-4100 Fax : 086 618 6462

DURBAN BRANCH Tel : (031) 569-6290 Fax : (031) 569-6296

EMAIL [info@macadams.co.za](mailto:info@macadams.co.za)

WEBSITE [www.macadams.co.za](http://www.macadams.co.za)